



HITZE

fireplaces | stoves | accessories

You have a choice.
Choose well.

Fireplace inserts



www.hitze.pl



ABOUT COMPANY

HITZE is a Polish producer of modern and ecological:

- fireplace inserts (air and water),
- free-standing stoves,
- bio fireplaces,
- garden hearths,
- fireplace accessories.

The wide product's range let customers to choose needed heating power with low emissions and modern design.

Many years of experience in the steel industry, production hall with an area of 3000 m² and a qualified team of specialists allow us to create products with the best technical parameters and high efficiency. Own technical laboratory enables continuous testing and improvement of fireplaces and stoves.



You have a choice.
Choose well.

112 FIREPLACE INSERTS

WITH THE POSSIBILITY OF PERSONALIZATION

NEW SYSTEM MAXVISION

TRINITY

The **MAXVISION SYSTEM** is a new series of **3 TRINITY fireplaces** with three-sided glazing giving a full and natural vision of fire. The minimalist design combined with enlarged glass perfectly complements the spacious interiors of modern homes.

NEW SYSTEM PREMIUM

ARDENTE

The **PREMIUM SYSTEM** is a series of **16 ARDENTE fireplaces** designed as a result of the best technical solutions from our offer. Available variants of DUO tunnel glazing and ease of use make them the best choice for the most demanding customers.

SYSTEM CUSTOM

ALBERO

The **CUSTOM SYSTEM** is a series of **36 ALBERO fireplaces**, which is the basic offer of the company with the greatest possibilities of personalizing the appearance of the fireplace. This series includes more than half the most popular corner models in a wide range of sizes and types of glazing.

SYSTEM EASY FIT

HST

The **EASY FIT SYSTEM** is a series of **18 HST fireplaces** created for casings with reduced depth. They are chosen mostly as decorative fireplaces or a heat source in passive houses and smaller rooms. The grateless combustion chamber is appreciated by customers who prefer to remove ash with a vacuum cleaner.

SYSTEM ECONOMY

STMA

The **ECONOMY SYSTEM** is a series of **9 STMA fireplaces** with a simplified design in standardized sizes. It meets the needs of everyone looking for reliability at an affordable price. Available installation accessories also reduce housing costs.

AQUASYSTEM

ALBERO

AQUASYSTEM is a series of **30 ALBERO fireplaces** adapted to work with central heating water installations. They guarantee the most effective use of burned wood to heat the entire house. They have the same possibilities of personalization as in the CUSTOM system what makes them unique among the market offer.

NEW

TRINITY



SYSTEM MAXVISION | Convection fireplace inserts | **3 models**

5 kW

ADJUSTABLE POWER RANGE

15,5 kW

The Hitze brand is still developing and creating new products. The TRINITY MODELS are the first fireplace inserts with the three-sided vision of fire on Hitze offer, occurring in three shapes of hearth.

Effective three-sided combustion chamber is a reflection of modern designs with maximum vision of fire. Designers have minimized the number of steel elements of the front and the door of the cartridge while maintaining durability and tightness of the furnace. In addition, the use of combined glass without printing maximizes the natural appearance of the furnace.

The use of a new opening mechanism - a guillotine with service access - gives tightness of the insert and increases safety against unattended opening by children. The design of the insert minimizes the effect of reversing smoke on the room when the door is opened.

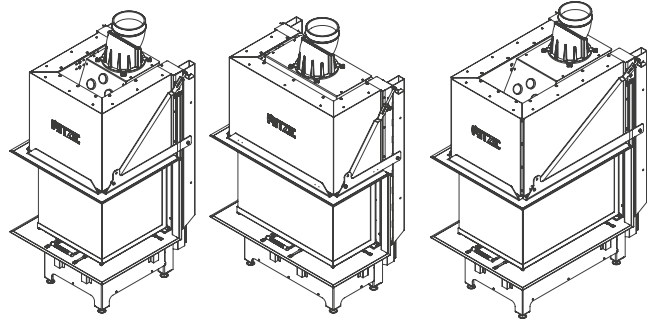

TRI54x54x53.G

TRI80x35x53.G

TRI54x80x53.G

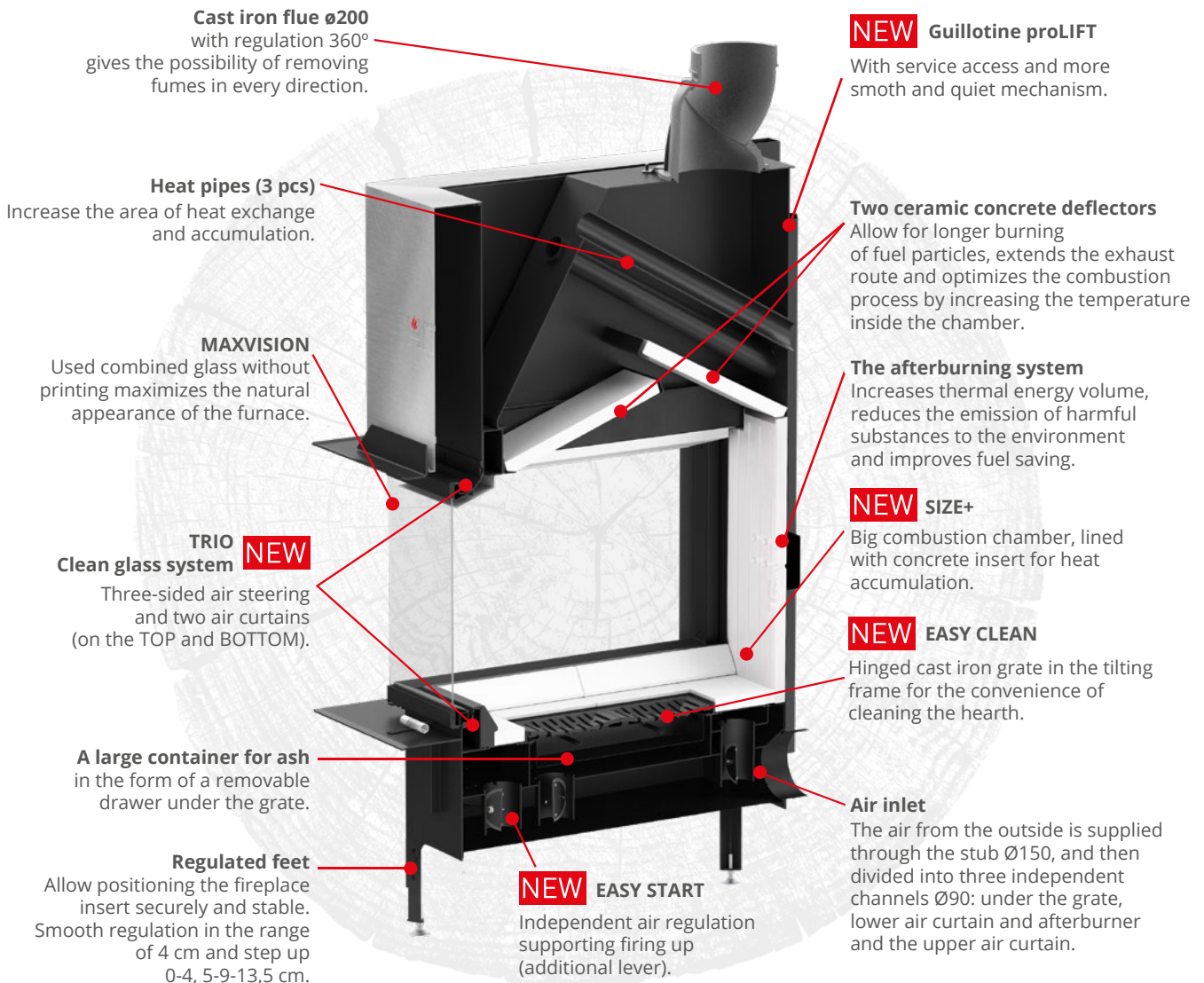

NEW

ARDENTE



SYSTEM PREMIUM | Convection fireplace inserts | **16 models**

6 kW

ADJUSTABLE POWER RANGE

28,5 kW

From the beginning the assumption of providing exceptional quality have determined the concept and technical solutions of fireplace inserts from the ARDENTE line. That's why they are the perfect choice for people who expect more from objects that create a home interior.

Quality in production is a philosophy of creating products that give satisfaction from use. That is why we conduct a rigorous selection of materials that make up our fireplaces. Comfortable burning and service as well as keeping the fireplace clean guarantee long-term satisfaction with a well-made decision. We are sure that you will appreciate the „small big“ changes that we have implemented in the ARDENTE models - our PREMIUM SYSTEM.

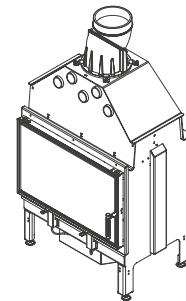

STANDARD .S

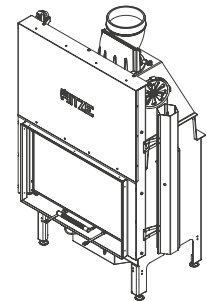

GUILLOTINE.G

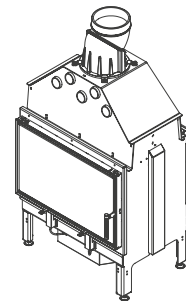

TWO-SIDED
STANDARD / STANDARD
.DSS

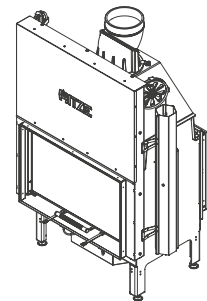

TWO-SIDED
GUILLOTINE / STANDARD
.DGS

Cast iron flue ø200 mm with regulation 360° guarantees tight connection of the fireplace to the chimney duct and ensures proper burning in the fireplace.

A solid steel body 30% higher weight*

Guillotine proLIFT NEW
With service access and more smooth and quiet mechanism.

Heat pipes increase the area of heat exchange and accumulation (from 3 to 6 pcs depending on the model).

DUO clean glass system NEW
Two-way air steering with air curtain.

Steel door made of a special profile that guarantees stiffness and high temperature durability.

DECOR ELEGANCE NEW
Glass with print, optional double glass system.

Regulated feet Allow positioning the fireplace insert securely and stable. Regulation in the range of 4 cm. **ADDITIONAL OPTION:** raising the feet in the height of +10 cm with adjustment +/- from 3 to 5 cm.

EASY CLEAN NEW
Hinged cast iron grate in the tilting frame for the convenience of cleaning the hearth.

Two ceramic concrete deflectors, optimize burning process due to the increase of temperature inside the chamber.

NEW TURBO BURN
New afterburning system increases thermal energy volume, reduces the emission of harmful substances to the environment and improves fuel saving.

NEW SIZE+
Cartridge with enlarged, deep rectangular combustion chamber giving the possibility of large loads.

NEW INTEGRATED AIR INLET
The air supply from the outside is realized through a single stub pipe and expansion boxes that distribute air to individual primary and secondary air intake pipes with integrated dampers.

*In comparison with the models from the Albero line.

ALBERO



SYSTEM CUSTOM | Convection fireplace inserts | **36 models**

4,5 kW

ADJUSTABLE POWER RANGE

32,5 kW

ALBERO line stands out by its light, modern form which integrates into every living space and usable floor space very well. It consists of six fireplace series differing in their heating power (9, 11, 14, 16, 19 and 25 kW), the vision of fire (straight or corner) and the way of the door opening (lifted up „guillotine” type or traditionally opened to the side).

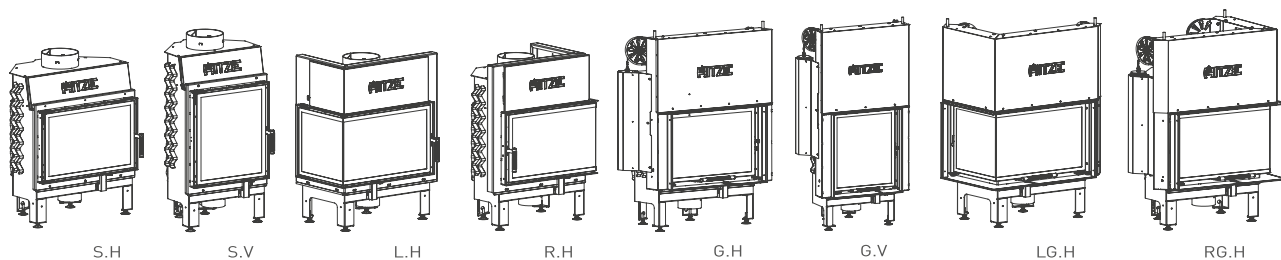

Fireplace inserts are equipped with an air inlet with a regulated throttle and special feet allowing for optimum leveling. The inside of the fireplace is lined with a special ceramic concrete insert. It accumulates warmth in the combustion chamber and is resistant to the temperature up to 1000°C. Air curtain reduces the deposition of soot on a ceramic glass pane and the after-burning system reduces the emission of harmful substances to the environment and improves fuel saving. A specially designed ventilated handle construction ensures the comfort of use, and steel door made of a profile of increased rigidity which guarantees tightness and strength.

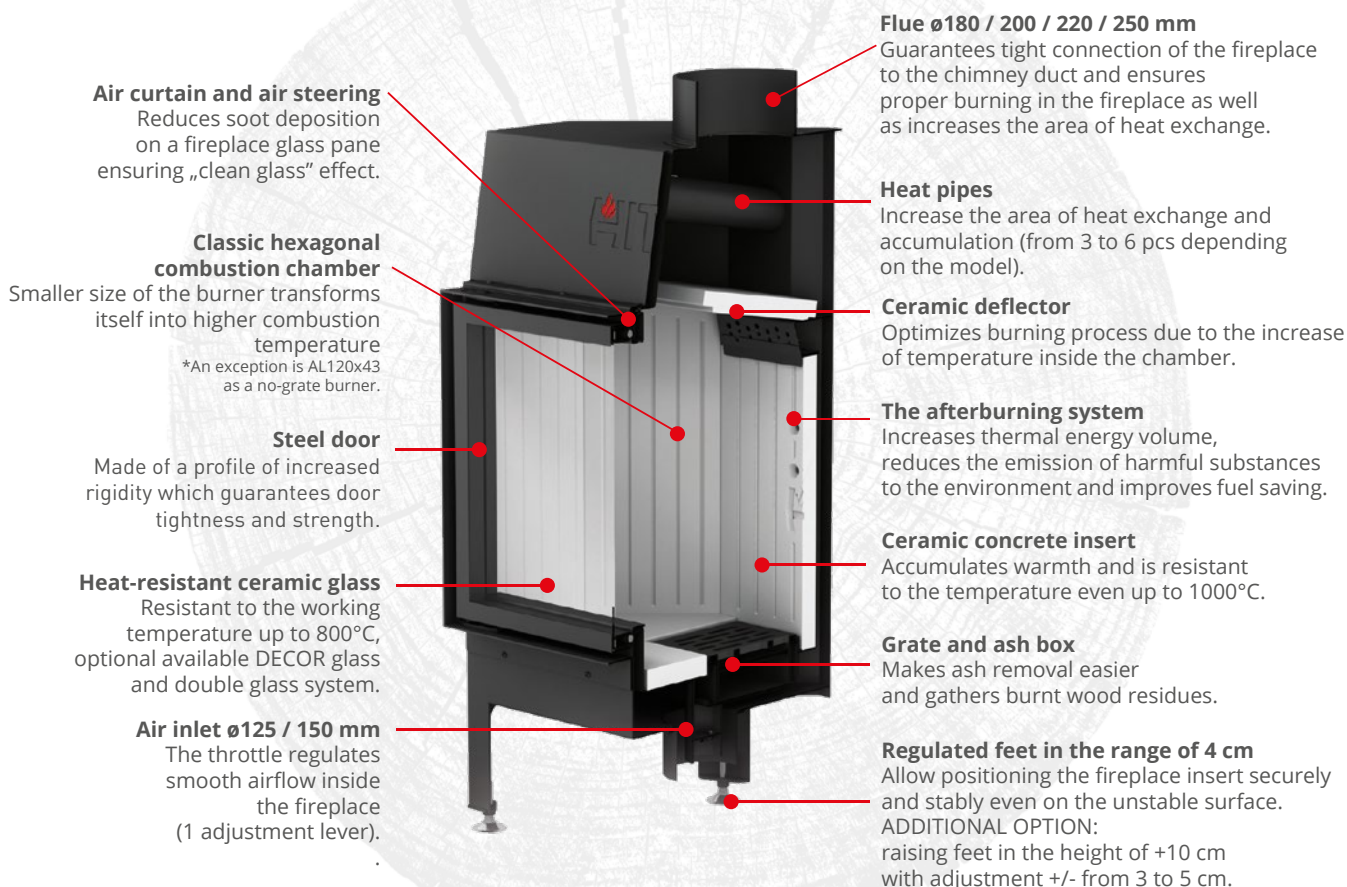

HST



SYSTEM EASY FIT | Convection fireplace inserts | **18 models**

3 kW

ADJUSTABLE POWER RANGE

17 kW

Fireplaces of HST line are inserts adapted to shallow encasing. Depending on the nominal power of a given model, they are dedicated to small usable areas as a recreational fireplace or an additional source of heating. The line consists of three sizes of inserts, appearing in six variants of the door opening (standard, right, left, guillotine, right guillotine, left guillotine).

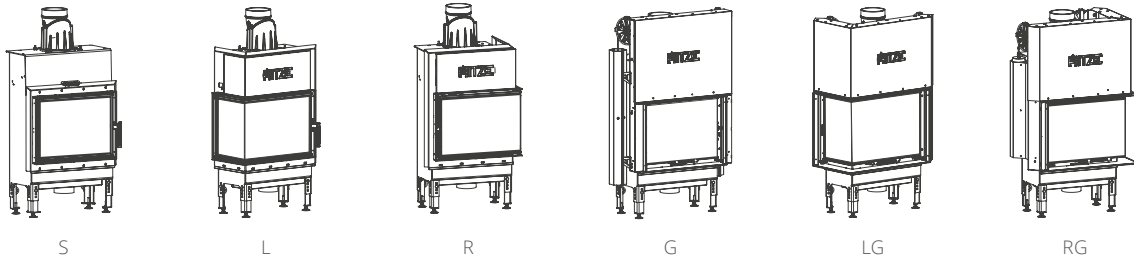

The standard equipment is: decorative DECOR pane, a double deflector (steel and ceramic), grateless combustion chamber, ventilated handle, 360 ° rotated cast iron flue, double smooth and step height adjustment of the legs and a common primary and secondary air control lever. The chamber is lined with warmth accumulating ceramic concrete.

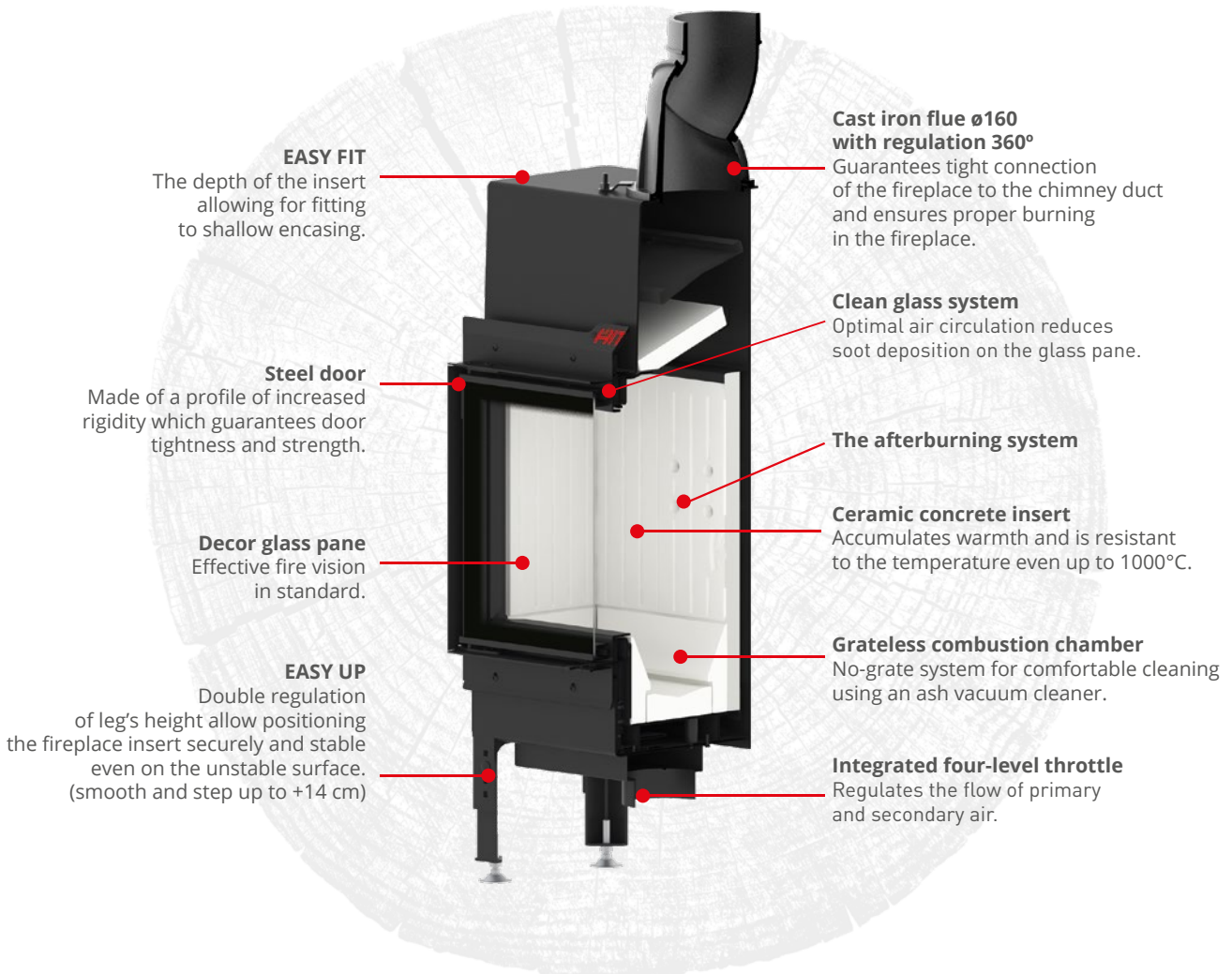

STMA



SYSTEM ECONOMY | Convection fireplace inserts | **9 models**

3 kW

ADJUSTABLE POWER RANGE

17 kW

The line of STMA fireplaces was created to extend to the offer of the Hitze Company. They are a response to the expectations of customers looking for an economical way to bring fire to the home.

Fireplaces from STMA line are available in 3 sizes of the combustion chamber. They are made with front or corner glassing, without the possibility of installing a guillotine door. In order to increase the design of the device, each model is equipped with printed DECOR glass in standard.

Despite the simplified steel construction, they were designed with the main technical solutions important for efficient and ecological combustion: two deflectors, post-combustion system, additional heat radiators and an accumulation lining into the combustion chamber.

For the convenience of cleaning and lighting the insert is equipped with a traditional and very well ventilated iron grate and ash pan. The simplicity of everyday use is achieved thanks to the integrated throttle of primary and secondary air.

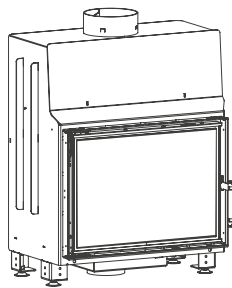

S

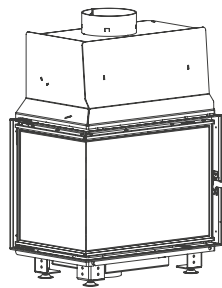

L

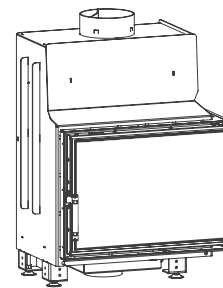

R

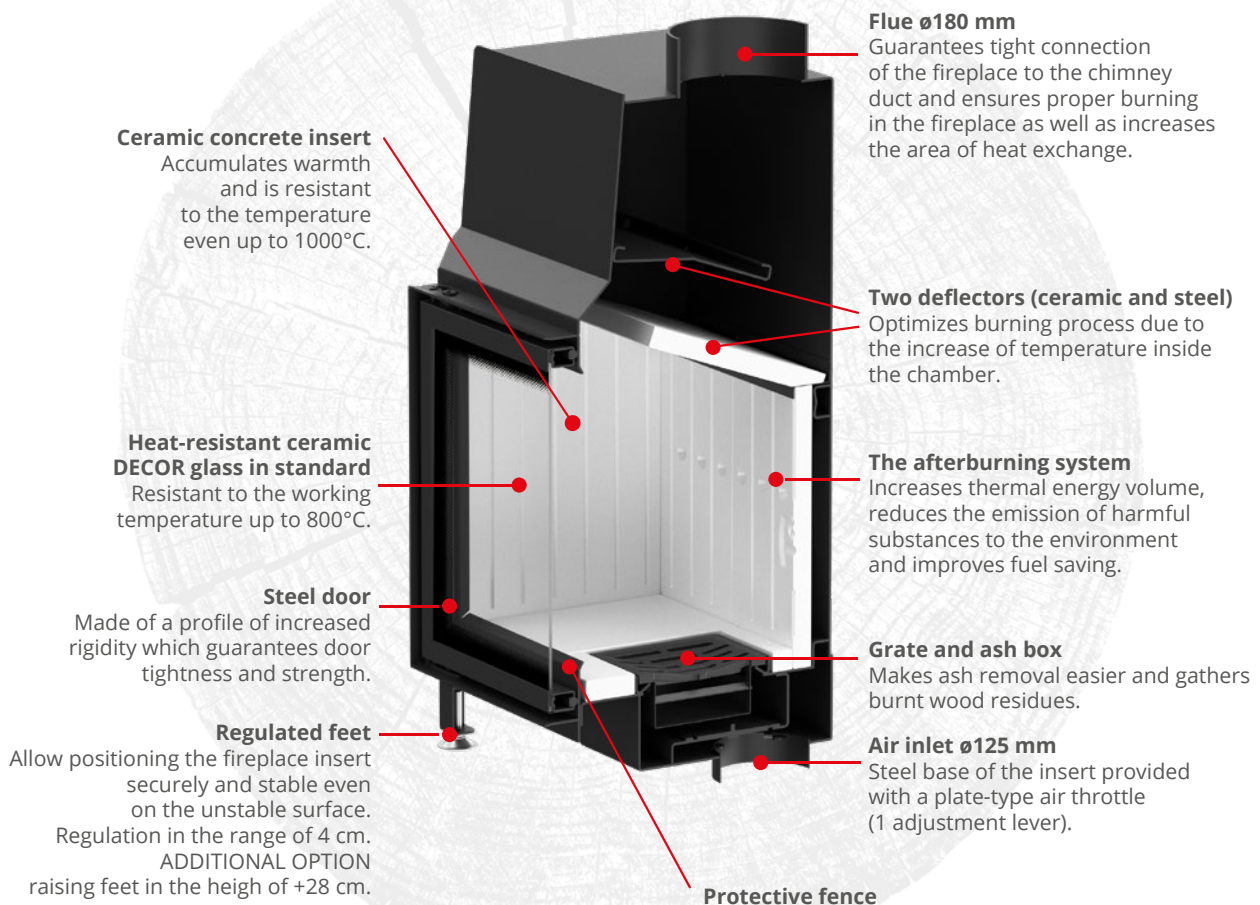

ALBERO



AQUASYSTEM | Water jacket fireplace inserts | **30 models**

5 kW

ADJUSTABLE POWER RANGE

27 kW

The economic and ecological line of fireplaces with a water jacket ALBERO AQUASYSTEM is a combination of a traditional fireplace insert with the function of water heating.

It consists of five series of fireplaces differing in heating power, the vision of fire (straight or corner) and the way of opening the door (lifted up „guillotine“ type or traditionally opened to the side). Fireplace inserts with a water jacket from the ALBERO AQUASYSTEM line can work independently in an open system and cooperate in a closed system with other heating devices, e.g. gas boilers, oil heaters, heat pumps, solar and photovoltaic systems. Inserts, in addition to the central heating function, can cooperate with the heaters storing hot water.

The water jacket is located above the combustion chamber. Specially designed rear part of the body allows for supplying secondary air to the upper part of the furnace and increases the efficiency of the device by burning off the fumes. The after-burning system reduces emissions of harmful substances into the environment and increases fuel economy.

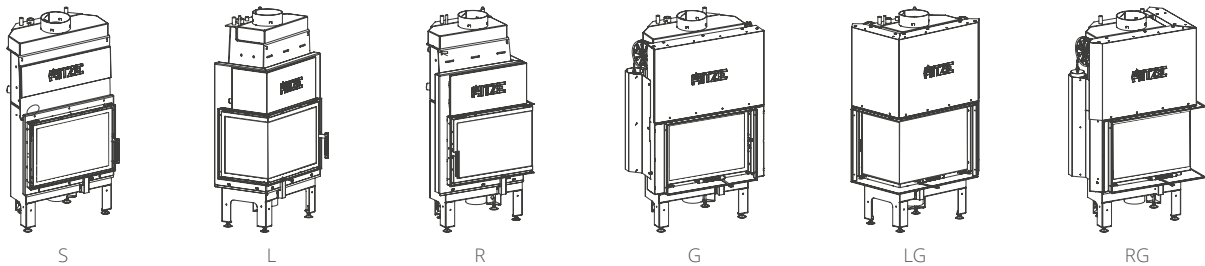

Flue ø180/200/220 mm

Guarantees tight connection of the fireplace to the chimney duct and ensures proper burning in the fireplace as well as increases the area of heat exchange.

Air curtain and air steering

Reduces soot deposition on a fireplace glass pane ensuring "clean glass" effect.

Steel door

Made of a profile of increased rigidity which guarantees door tightness and strength.

Heat-resistant ceramic glass

Resistant to the working temperature up to 800°C, optional available DECOR glass and double glass system.

Regulated feet in the range of 4 cm.

Allow positioning the fireplace insert securely and stably even on the unstable surface.
ADDITIONAL OPTION:
raising feet in the height of +10 cm with adjustment +/- from 3 to 5 cm.

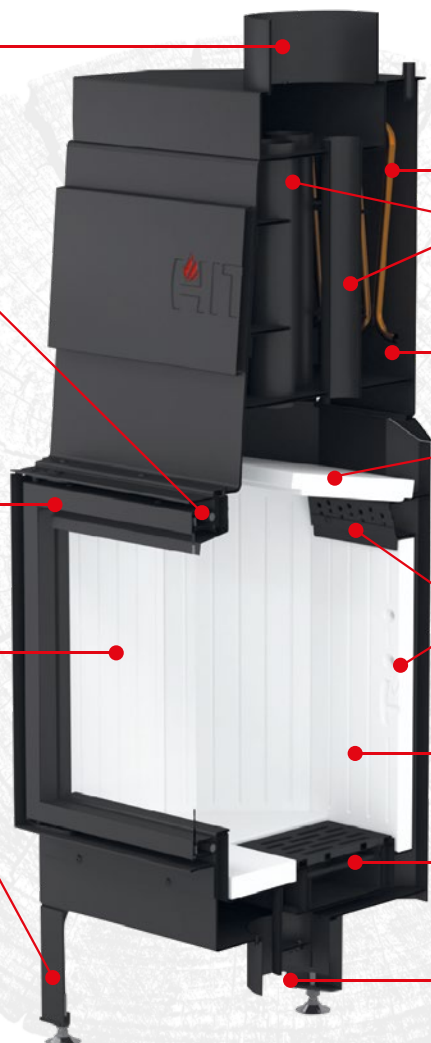

Coil

Protects the jacket against overheating.

Smoke tubes

They strengthen the process of heating the water in the water jacket.

ENERGY+

Heater/water jacket is made of 4 mm thick boiler steel.

Ceramic deflector

Optimizes burning process due to the increase of temperature inside the chamber.

The afterburning system

Increases thermal energy volume, reduces the emission of harmful substances to the environment and improves fuel saving.

Combustion chamber

lined with ceramic concrete on the bottom, on the side walls and on the rear wall.

Grate and ash box

makes ash removal easier and gathers burnt wood residues.

Air inlet ø125 mm

the throttle regulates smooth airflow inside the fireplace (1 adjustment lever).



INSTALLATION ACCESSORIES:

HEAT EXCHANGERS



WCPW01.Fi200
WCPW01Fi180 **NEW**
heat exchanger
with water jacket
material:
boiler steel 3 mm
kW < 7 kW
kW < 7 kW



WCPW01w.Fi200
WCPW01wFi180 **NEW**
heat exchanger with water
jacket and coil pipe
material:
boiler steel 3 mm
kW < 7 kW
kW < 7 kW

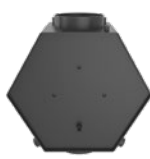

WCPW02.Fi200
heat exchanger
with water jacket
and tubes
material:
boiler steel 4 mm
kW < 10 kW



WCPP01.Fi200
WCPP01Fi180 **NEW**
air heat exchange
material:
boiler steel 3 mm
kW < 7 kW
kW < 7 kW

ACCUMULATION SET



Block weight: 14,5 kg
For the lines:
ALBERO
ALBERO AQUASYSTEM
ARDENTE
HST
STMA

ADDITIONAL FEET



For the lines:
ALBERO
ALBERO AQUASYSTEM
STMA
ARDENTE

VENTILATION GRIDS

DECCO

Available in various colors and sizes.
Material: steel with a thickness of 1.5 mm.
Mounting frame included.



W B



DECCO
size: 20 x 20 cm
KDC-20x20-W

DECCO
size: 20 x 30 cm
KDC-20x30-W

DECCO
size: 20 x 40 cm
KDC-20x40-W

DECCO
size: 20 x 50 cm
KDC-20x50-W

SLIM

Available in various shapes and sizes.
Shapes: straight and corner
Material: steel with a thickness of 1.5 mm



W B



SLIM INOX

Available in various shapes and sizes.
Base colors: black
Finish: stainless steel, polished
Shapes: straight and corner
Material: steel with a thickness of 1.5 mm



B

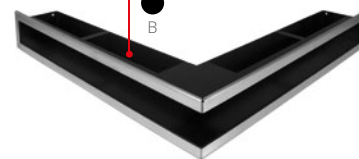

FIREPLACE PERSONALIZATION:

STANDARD OPENING



INOX VENT



NEW

INOX VENT
PORTAL



BLACK VENT



NEW

BLACK VENT
PORTAL



BLACK BASIC

GUILLOTINE OPENING (available in 5 sizes)



INOX VENT G



BLACK VENT G



BLACK MINIMAL G

MASKING FRAMES

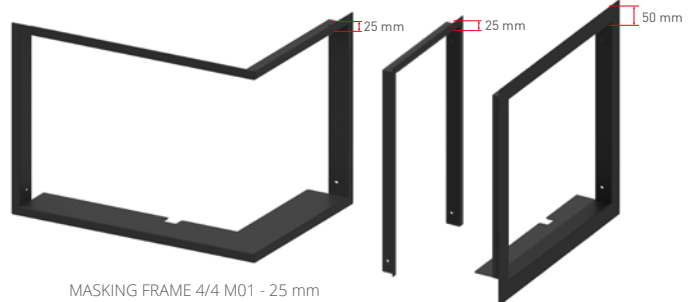

MASKING FRAME 4/4 M01 - 25 mm

MASKING FRAME 3/4 M02 - 25 mm

MASKING FRAME 4/4 M03 - 50 mm

NEW MASKING FRAME 4/4 M04 - 25 mm / depth 79 mm*

* ±1 mm depending on the model

BLACK CERAMIC CONCRETE INSERT available for all models



BIO-INSERTS

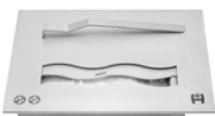

SMALL WBN-04
MEDIUM WBN-02
LARGE WBN-03

GLASS BASES



BASE 01

Dimensions (mm) 515 x 350

BASE 02

Dimensions (mm) 1067 x 1260

Material: tempered glass

CERAMIC GLASS DECOR:

NEW

pattern DECOR *Elegance*

EQUIPMENT CONFIGURATION		Albero	Albero Aquasystem	HST	STMA	Ardente	Trinity
Number of models		36	30	18	9	16	3
Glass	Straight front glass pane	•	•	•	•	•	-
	Combined glass pane	•	•	•	•	-	-
	Tunnel glass pane	-	-	-	-	•	-
	Three-way glass pane	-	-	-	-	-	•
	DECOR glass pane (standard or elegance)	+	+	•	•	• ELEGANCE	-
	Bent glass in corner models	•	•	-	-	-	-
	Double glass	+	+	+	+	+	-
Door	Standard opening (hinge)	•	•	•	•	•	-
	Opening a guillotine type	•	•	•	-	• PROLIFT	• PROLIFT
	Change in the direction of opening - standard doors (front straight)	•	•	•	•	•	-
Combustion chamber	Combustion chamber lined with black ceramic concreteinsert accumulating warmth	+	+	+	+	+ SIZE+	+ SIZE+
	Cast iron grate	•*	•	-	•	• EASY CLEAN	• EASY CLEAN
	Air curtain	•	•	•	-	• DUO	•** TRIO
	Air steering	•	•	•	•	• DUO	• TRIO
	The afterburning system	•	•	•	•	• TURBO BURN	•
	Fireplaces for recuperation	•	•	•	•	•	•
Body	Air inlet	•	•	•	•	•	•
	Integrated air throttle	• x1	• x1	• x1	• x1	• x2	• x3
	Regulated feet (0-4 cm)	•	•	•	•	•	•
	Additional feet lift	+	+	• EASY UP	+	+	• EASY UP
	Heat pipes	•	•	-	-	•	•
	Ceramic deflectors	•	•	•	-	• x2	• x2
	Steel deflector	-	-	•	•	-	-
	Cast iron flue 360°	-	-	•	-	•	•
Additional accessories	Masking Frame 4/4 - M01 - 25 mm	+	+	+	+	+	-
	Masking Frame 3/4 - M02 - 25 mm	+	+	-	-	-	-
	Masking Frame 4/4 - M03 - 50 mm	+	+	+	+	+	-
	Masking Frame 4/4 - M04 - 25 mm (depth 79 mm****) (for order)	+	+	+	+	-	-
	Serial Handle	INOX VENT	INOX VENT	INOX VENT	BLACK BASIC	INOX VENT	INOX VENT
	Bio-insert	+	+	+	+	+***	+
	Accumulation set	+	+	+	+	+	+

- Available as standard
- Unavailable
- + The option is available at extra cost

- * Except AL120x43G.H model, having grateless furnace
- ** The Trinity line has an additional lower air curtain for the entire width of the glass
- *** Applies to ARD 68x43 and ARD 68x53 models
- **** ±1 mm depending on the model

Find a model that fits your interior:

GLASS DIMENSIONS width x height [cm]	Albero	Albero Aquasystem	HST	STMA	Ardente	Trinity
39 x 54	AL9.V	-	-	-	-	-
43 x 59	AL11.V	-	-	-	-	-
43 x 68	AL14.V	-	-	-	-	-
54 x 39	AL9.H L/R: 32,5 cm	ALAQ54x39 L/R: 37,5 cm	HST54x39 L/R: 29,5 cm	STMA54x39 L/R: 34,7 cm	-	-
54 x 53	-	-	-	-	-	TRI54x54x53.G TRI54x80x53.G
59 x 43	AL11.H L/R: 37,5 cm	ALAQ59x43 L/R: 37,5 cm	HST59x43 L/R: 29,5 cm	STMA59x43 L/R: 34,7 cm	-	-
68 x 43	AL14.H L/R: 37,5 cm	ALAQ68x43 L/R: 37,5 cm	HST68x43 L/R: 29,5 cm	STMA68x43 L/R: 34,7 cm	ARD68x43	-
68 x 53	AL16.H L/R: 37,5 cm	ALAQ68x53 L/R: 37,5 cm	-	-	ARD68x53	-
80 x 53	-	-	-	-	-	TRI80x35x53.G
90 x 41	AL19.H L/R: 37,5 cm	ALAQ90x41 L/R: 37,5 cm	-	-	ARD90x41	-
105 x 43	-	-	-	-	ARD105x43	-
120 x 43	AL120x43G.H	-	-	-	ARD120x43	-

Enter the world of NATURAL HEATING and see more!

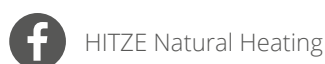

www.hitze.pl

RAL colours presented on product visualisations are for reference only and their shades may slightly differ from the real colour.

Hitze company reserves the right to introduce changes in the technical parameters, equipment and specifications of the offered products. The information in the catalog is for information purposes only and does not constitute an offer within the meaning of the Civil Code.

STALKO
spółka z ograniczoną odpowiedzialnością
spółka komandytowa (dawniej HITZE sp. z o.o.)
ul. Solec 24/253
00-403 Warszawa, POLAND

Office
ul. Gdyńska 32
26-600 Radom
POLAND

+48 48 380 18 98
+48 800 88 00 30
export@hitze.pl

VAT PL9482603545
REGON 361379132
Reg. No. 0000836475