

BASIC INFORMATION ABOUT THE PRODUCT



- Designer elliptical shape.
- Designed for recuperation.
- Adapted to the DGP system.
- High thermal efficiency.
- Fireplace glass withstands up to 800°C.
- Polished on both sides, transparent fireplace ceramics.
- Accumulatory lining that increases the temperature of combustion processes.
- Three-stage combustion air system.
- The use of P265GH boiler sheet in the body structure.
- High-temperature, anti-corrosion paint coating.
- Possibility to choose from several versions of the base.
- Wood compartment or storage compartment with click system

Nominal power [kW]	5,3
Heating load range [kW]	2,5-7
Thermal efficiency [%]	80,6
CO emissions (at 13% O2) [g/m3]	0,032
Pollen emission [g/m3]	0,952
Average fuel consumption [kg/h]	1,7
Glass dimensions [mm]	461 x 648
Flue diameter [mm]	146
Inlet diameter [mm]	100
Weight [kg]	117
Efficiency factor	106,9



**ELLISSES**

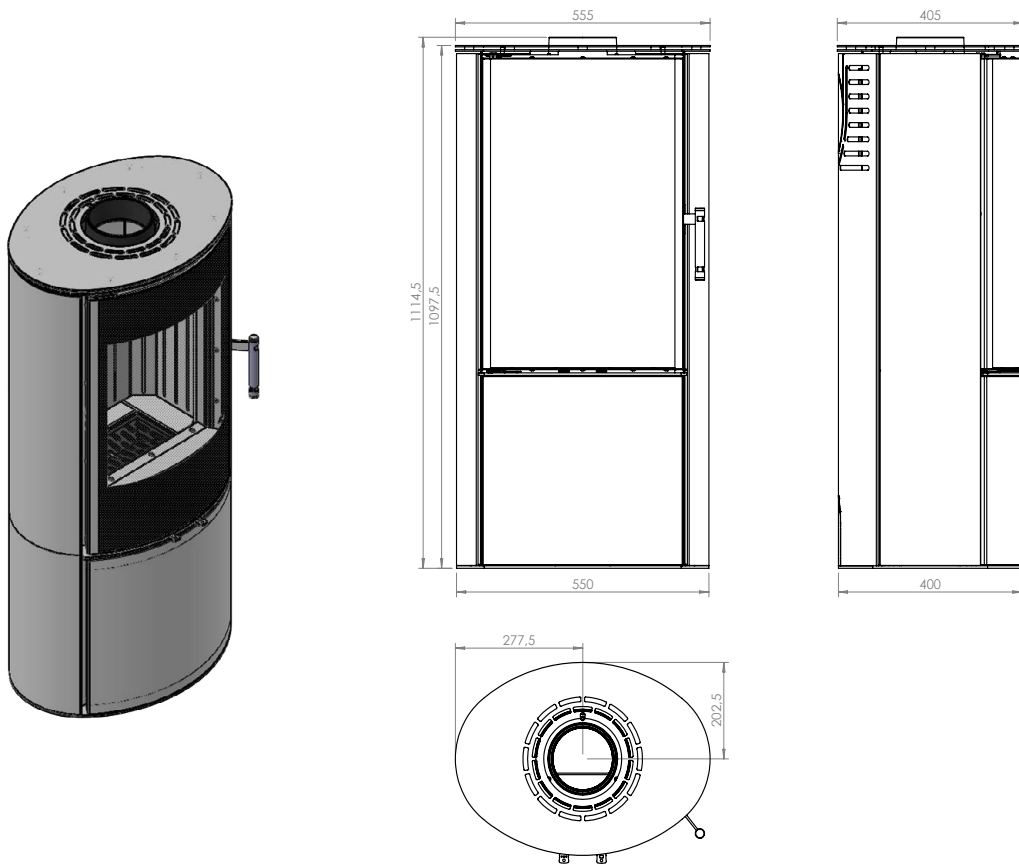

# ELLISES