



CALMA

80TU

HITZE

PRODUCER OF FIREPLACES

B**ENERGY CLASS****GAS FIREPLACE INSERT**

BASIC PRODUCT INFORMATION



- CALMA fireplaces work with different types of gas (G20, G27, G30, G31), offering flexibility of use.
- Designed to work with POUJOLAT air-flue systems, they provide safe flue gas extraction.
- They offer three installation options (through the wall, roof, existing chimney), increasing their installation versatility.
- The raised glazing of the CALMA fireplaces provides an extended vision of the fire and interior elegance.
- Easy remote control operation and collaboration with smart home systems for convenience of use.
- High quality, certification and compliance with the Ecodesign 2022 Directive guarantee reliability and environmental compatibility.

Fuel type	High-methane natural gas, nitrogenated natural gas, propane-butane gas mixture, propane gas
Rated power [kW]	10,8
Power range [kW]	6,7 - 10,8
Clear glass height [mm]	485
Chimney system [mm].	150/100
Control valve	Maxitrol GV60 or Anstoss TESCO1
Weight [kg]	143 - 151

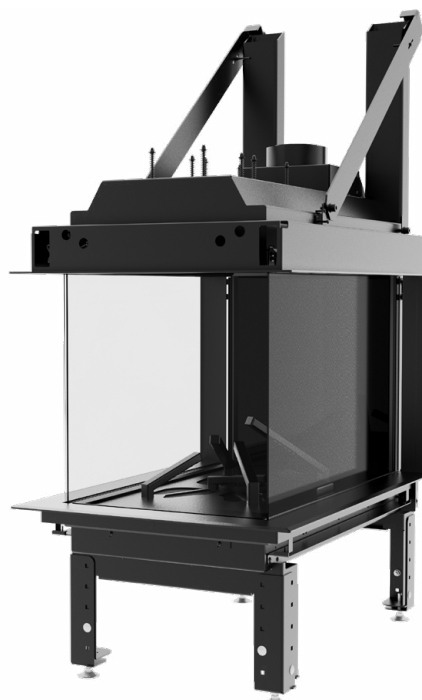
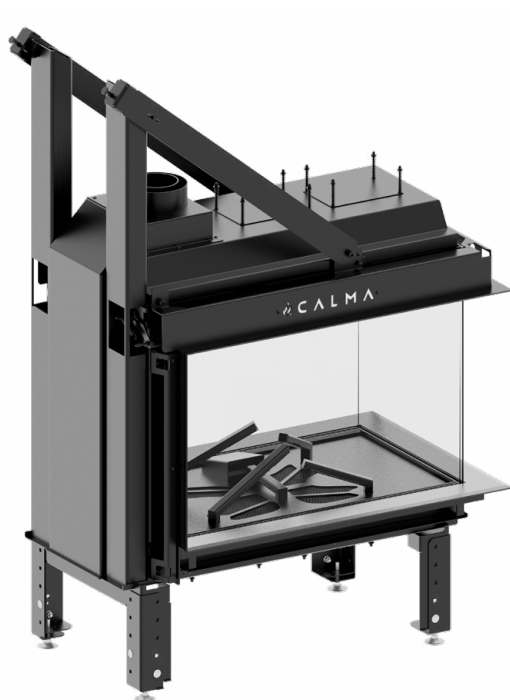

UP TO **8** years
WARRANTY

SAFETY
LAB CERTIFICATE
KIWA

FIREPLACE
FOR RECUPERATION

ELEGANT
DESIGN

80TU

